

MA40-704X, MA41-707/715X Series

SmartX Spring Return Two-Position Actuators

Application

SmartX™ Direct Coupled Actuators are designed to be used in both damper and valve control applications. The following general instructions are for damper applications, refer to the Applicable Literature table for valve literature.

The MA40-704X, MA41-707X and MA41-715X series spring return actuators are used for the on-off, fail safe control of dampers and valves in HVAC systems.

Features

- Two-position actuator controlled by SPST controller
- 133 lb-in (15 N-m), 60 lb-in (7 N-m), and 35 lb-in (4 N-m) torque models
- 24 Vac/DC, 120 Vac, and 230 Vac models
- Rugged die cast housings rated for NEMA 2 / IP54
- Overload protection throughout rotation
- Optional built-in auxiliary switch to provide for interfacing or signaling
- Provides 95° of rotation
- Visual position indicator provided
- Provides true mechanical clockwise or counterclockwise spring return operation for reliable fail safe application and positive close-off in air tight damper applications
- Direct mount to round or square damper shafts
- Rotation limiting available
- MA41-7153 series actuators can be double-mounted (gang mounting) to accommodate high torque application requirements
- Five year warranty
- MA41-707X-XXX and MA41-715X-XXX equipped with manual override

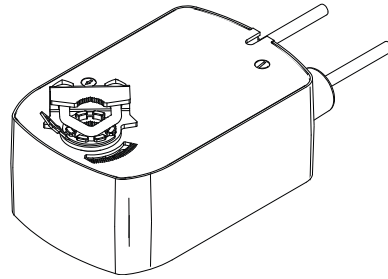

MA40-704X

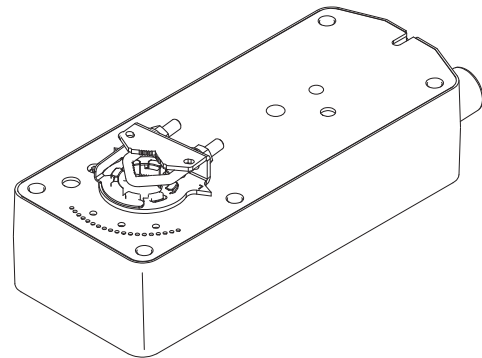

MA41-707X
MA41-715X

Life Is On

Schneider
Electric

Applicable Literature

F-Number	Description	Audience	Purpose
F-26750	MX40-6XXX-2XX, MX4X-7XXX-2XX Series Actuator/Linkage Assemblies General Instructions	Sales Personnel Application Engineers Installers Service Personnel Start-up Technicians	Describes the globe valve actuator/linkage assembly's features, specifications, and possible applications. Provides step-by-step mounting instructions.
F-26751	VX-2000 Series Ball Valve Assembly Installations Instructions	Sales Personnel Application Engineers Installers Service Personnel Start-up Technicians	Describes the actuator/linkage/ball valve assembly's features, specifications, and possible applications. Provides step-by-step mounting instructions.
F-26646	MX4X-7XXX, MX40-6XXX Series SmartX Actuator Selection Guide	Sales Personnel Application Engineers Installers Service Personnel Start-up Technicians	Provides actuator specifications and part number cross referencing of phased out actuators with the new direct-coupled actuators.
F-26752	VX-2000, VX-7000 Series Ball/Linked Globe Linked Valve Assemblies Actuator/Linkage Assemblies Selection Guide	Sales Personnel Application Engineers Installers Service Personnel Start-up Technicians	Provides part number cross referencing of phased out globe and ball valve assemblies with the new direct-coupled actuators.
F-26080	EN-205 Water System Guidelines	Application Engineers Installers Service Personnel Start-up Technicians	Describes Schneider Electric approved water treatment practices.
F-13755	CA-28 Control Valve Sizing	Application Engineers Installers Service Personnel Start-up Technicians	Provides charts, equations, and diagrams to assist in the configuration of valve system applications. TOOL-150, valve sizing slide rule may be purchased separately.
F-11080	Valve Selection Chart Water		
F-11366	Valve Selection Chart Steam (two-way valves only)		

Specifications

Actuator Inputs	
Control Signal	On-off, spring return. SPST control contacts or Triacs (500 mA rated).
Power Input	See Table-1. All 24 Vac circuits are Class 2. All circuits 30 Vac and above are Class 1.
Connections	3 ft. (91 cm) appliance cables 1/2 in. conduit connector. For M20 Metric conduit, use AM-756 adaptor.
Actuator Outputs	
Electrical: Auxiliary Switches	
MA41-715X-502 and MA41-707X-502	Two SPDT 7A (2.5A) @250 Vac, UL listed; one fixed @ 5° and one adjustable 25 to 85°
MA40-7040-501 and MA40-7041-501	One SPDT 6A (1.5A) @250 Vac, UL listed; adjustable 15 to 95° (MIN to 1 scale)
MA40-7043-501	One SPDT 6A (1.5A) @24 Vac, UL listed; adjustable 15 to 95° (MIN to 1 scale).
Mechanical	
Stroke, Angle of rotation	95° ± 5° maximum. Adjustable 30° to 95° with AM-689 installed on MA41-715X or MA41-707X series. Stroke limiter is standard on MA40-704X series.
Damper Shaft Clamp	
MA40-704X	The factory installed universal clamp is used for shafts up to 5/8" (15 mm) diameter or up to 1/2" (13 mm) square. AM-710 accessory clamp is required when mounting actuators to shafts up to 3/4" (19 mm) diameter or up to 1/2" (13 mm) square.
MA41-715X or MA41-707X	The factory installed universal clamp is used for shafts up to 3/4" (19 mm) diameter or up to 1/2" (13 mm) square. AM-687 accessory clamp is required when mounting actuators to shafts up to 1.05" (27 mm) in diameter or up to 5/8" (15 mm) square.

Position Indicator	Visual indicator
MA41-715X and MA41-707X	-5 to 90° (-5° is spring return position)
MA40-704X	0 to 1 (0 is spring return position)
Nominal Damper Area	Actuator sizing should be done in accordance with damper manufacturer's specification.
Direction of Rotation	Clockwise or counterclockwise rotation determined by actuator mounting
Manual Override	
MA41-707X and MA41-715X rotation	adjustable from -5° to 85° using manual override crank
Environment	
Ambient Temperature Limits	
Shipping & Storage	-40 F to 160°F (-40 to 71°C)
Operating	-22 to 140°F (-30 to 60°C)
Humidity	15 to 95% RH, non-condensing
Enclosure Rating	
MA41-715X and MA41-707X	NEMA 1 (IEC IP30). NEMA 2 (IEC IP54) with conduit connector in the down position
MA40-704X	NEMA 2 (IEC IP54) no restrictions
Agency Listings	
UL 873	Underwriters Laboratories (File # E9429 Category Temperature -Indicating and Regulating Equipment).
CUL	UL Listed for use in Canada by Underwriters Laboratories.
European Community	Canadian Standards C22.2 No. 24. EMC Directive (89/336/EEC). Low Voltage Directive (72/23/EEC).
Australia	This product meets requirements to bear the RSM Mark according to the terms specified by the Communications Authority under the Radiocommunications Act 1992.

Available Models

Part Numbers	Actuator Power Input								Auxiliary Switch	Approximate Timing in Seconds @ 70° (21°C) ^a		Output Torque Rating lb-in (N-m) ^b										
	Voltage	VA Hz		Watts				Powered		Spring Return	Minimum	Maximum Stall	Manual Override									
		50	60	Running Hz		DC Amps	Holding Hz															
				50	60		50							60								
MA41-7153	24 Vac ± 20% 22...30 Vdc	9.8	9.7	7.5	7.5	0.29	2.8	2.8	No	<190	<30	133 (15)	350 (40)	Yes								
MA41-7153-502				7.5	7.5				Two ^c					Yes								
MA41-7150	120 Vac ± 10%	11.7	10.0	8.8	8.4	—	3.6	5.0	No					<80	<40	60 (7)	250 (28)	Yes				
MA41-7150-502				8.8	8.4				Two ^c									Yes				
MA41-7151	230 Vac ± 10%	15.5	10.6	9.5	8.5	—	4.6	3.3	No									<50	<26	35 (4)	150 (17)	Yes
MA41-7151-502				9.5	8.5				Two ^c													Yes
MA41-7073	24 Vac ± 20% 22...30 Vdc	4.8	4.8	3.2	3.2	0.13	0.8	0.8	No	<50	<26	35 (4)	150 (17)									Yes
MA41-7073-502				3.2	3.2				Two ^c													Yes
MA41-7070	120 Vac ± 10%	10.7	5.6	4.2	3.6	—	2.0	1.2	No					<50	<26	35 (4)	150 (17)					Yes
MA41-7070-502				4.2	3.6				Two ^c													Yes
MA41-7071	230 Vac ± 10%	17.0	8.0	5.1	4.0	—	2.7	1.4	No									<50	<26	35 (4)	150 (17)	Yes
MA41-7071-502				5.1	4.0				Two ^c													Yes
MA40-7043	24 Vac ± 20% 22...30 Vdc	4.4	4.4	2.9	2.9	0.11	0.8	0.8	No	<50	<26	35 (4)	150 (17)									No
MA40-7043-501				2.9	2.9				One													No
MA40-7040	120 Vac ± 10%	6.4	4.3	3.8	3.4	—	1.6	1.2	No					<50	<26	35 (4)	150 (17)					No
MA40-7040-501				3.8	3.4				One ^d													No
MA40-7041	230 Vac ± 10%	5.8	4.6	4.1	3.9	—	1.5	1.2	No									<50	<26	35 (4)	150 (17)	No
MA40-7041-501				4.1	3.9				One ^d													No

- a - Timing was measured with no load applied to the actuator.
- b - De-rating is required at low temperatures.
- c - One adjustable from 25 to 85° rotation and one set to operate @ 5° fixed.
- d - One adjustable from 15 to 95° rotation (MIN to 1 scale)

Accessories

For use with MA41-7XXX:

- AM-671 Universal Mounting Bracket, AM-693 is required
- AM-672 Universal Mounting Bracket, AM-693 is required
- AM-673 Mounting Bracket
- AM-674 Weather Shield
- AM-675 Base Mounting Plate for AM-674
- AM-676 Universal Shaft Extension
- AM-714 Weather Shield (polycarbonate)
- AM-756 Metric Conduit Adapter M20 x 1.5 to 1/2" NPT
- AM-761 7-inch Anti-rotation Bracket
- AM-762 9-inch Anti-rotation Bracket

For use with MA40-7043:

- AM-709 Position Indicator and Stroke Limiter
- AM-710 Universal Clamp for up to 3/4" diameter shafts
- AM-711 Crankarm for up to 1/2" round shaft
- AM-712 Crankarm Adapter Kit
- AM-713 Mounting Bracket for Honeywell Mod IV, M6415 type actuators and new installations
- AM-715 Crankarm Adapter Kit for Honeywell Mod IV, M6415 type actuators and new installations

For use with MA41-7073, MA41-7153

- AM-686 Damper Position Indicator
- AM-687 Universal Clamp for up to 1.05" (27 mm) diameter shafts
- AM-688 Replacement Universal Clamp
- AM-689 Rotation Limiter
- AM-690 Crankarm for round shafts up to 3/4" (19 mm)
- AM-691 Crankarm for jackshafts up to 1.05" (27 mm)
- AM-692 V-bolt Kit for AM-690 and AM-691 Crankarm
- AM-693 Damper Linkage Kit
- AM-758 Short "U" Mounting Bracket
- AM-759 Tall "U" Mounting Bracket
- AM-760 Slotted "L" Mounting Bracket
- AM-763 1/8" Hex Crank for Manual Override

TYPICAL APPLICATIONS (wiring diagrams)

Figure-1 through Figure-3 illustrate typical wiring diagrams for spring return floating actuators. See Available Models.

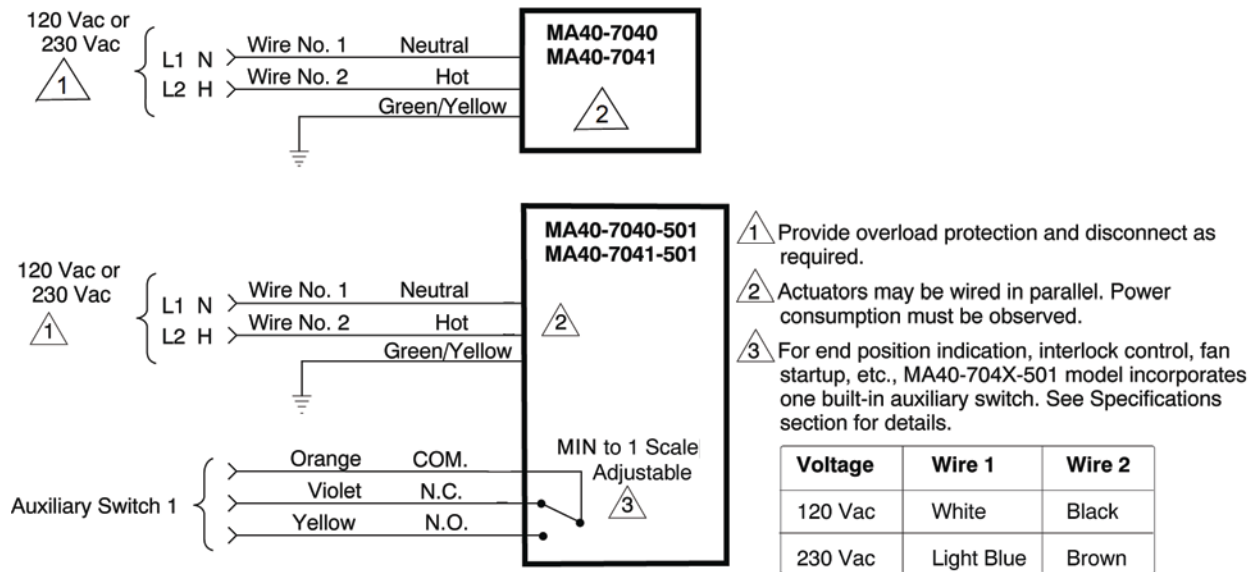

Figure 1 Typical Wiring Diagram for 24 Vac Basic and Double Auxiliary Switch Models.

MA41-707X-502 and MA41-715X-502 units manufactured prior to the date code 0141 (October 6, 2001) used the following color coding for the auxiliary switches:

Auxiliary Switch 1

- Orange: Fixed auxiliary switch common (com)
- Yellow: Fixed auxiliary switch normally closed (NC)
- Violet: Fixed auxiliary switch normally open (NO)

Auxiliary Switch 2

- Orange/white: Adjustable auxiliary switch common (com)
- Violet/white: Adjustable auxiliary switch normally closed (NC)
- Yellow/white: Adjustable auxiliary switch normally open (NO)

The label information on these units is incorrect. If replacing these units, the auxiliary switch operation of the replacement actuator will be per the product label.

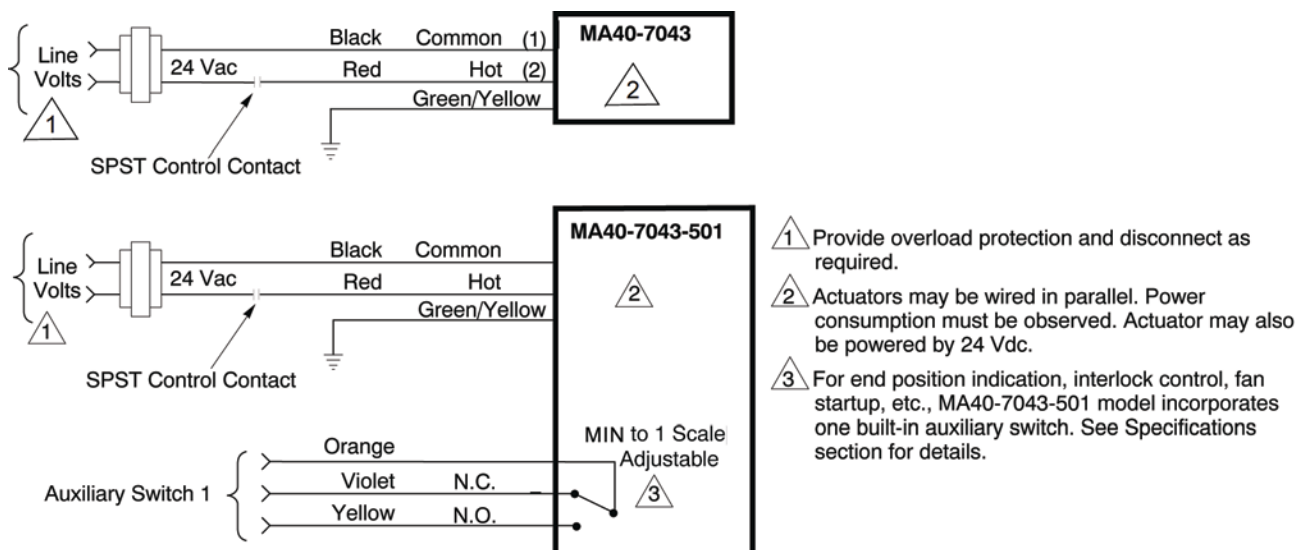

Figure 2 Typical Wiring Diagram for 120 Vac or 230 Vac Basic and Single Auxiliary Switch Models.

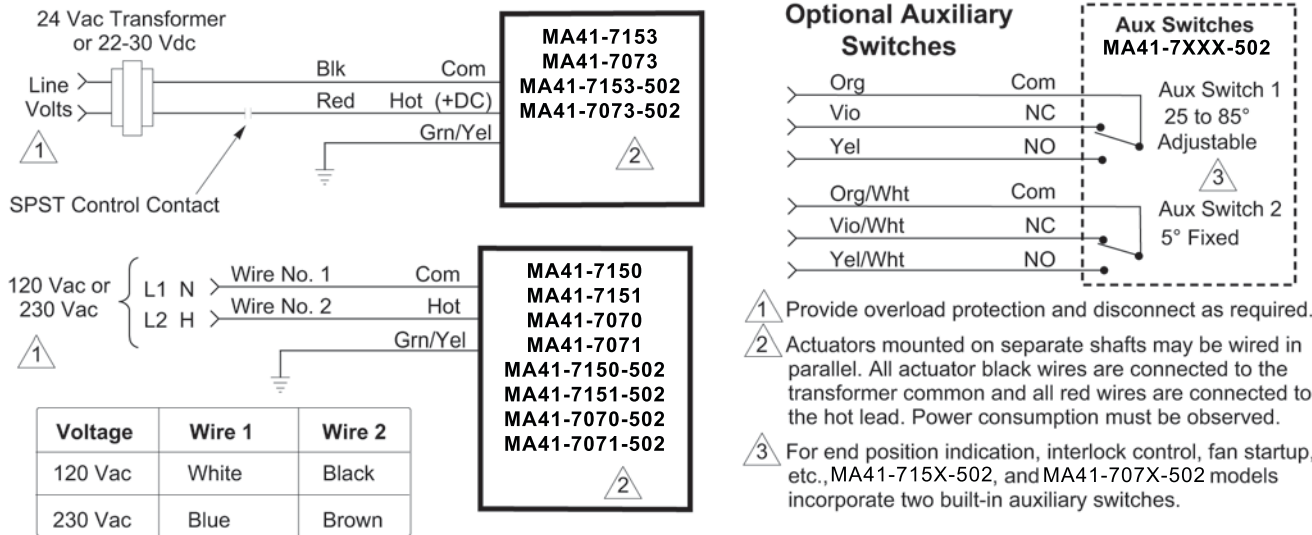

Figure 3 Typical Wiring Diagram for 24 Vac Basic and Single Auxiliary Switch Models.

Installation

Inspection

Inspect the package for damage. If damaged, notify the appropriate carrier immediately. If undamaged, open the package and inspect the device for obvious damage. Return damaged products.

Requirements

- Job wiring diagrams
- Tools (not provided):
 - #8 sheet metal screws
 - 10mm open end wrench or socket wrench
 - 7/16 inch, open end wrench or socket wrench
 - 1/8 inch, allen wrench
 - Appropriate screwdriver(s)
- Appropriate accessories
- Training: Installer must be a qualified, experienced technician

Precautions

Notices

- Electrical shock hazard! Disconnect the power supply (line power) before installation to prevent electric shock and equipment damage.
- Make all connections in accordance with the job wiring diagram and in accordance with national and local electrical codes. Use copper conductors only.
- Avoid electrical noise interference. Do not install near large contactors, electrical machinery, or welding equipment.
- Do not drill holes in actuator body. Six pre-drilled holes are located on each side, under the label, to accept #10-24 thread-forming screws for mounting accessories.

Manual Override

The MX41-707X & MX41-715X actuators are equipped with a manual override.

- The manual override is to be used only when power is not applied to the unit.

- If the universal clamp is not set to 0° on the position indicator, manually wind the actuator in the direction indicated with hex wrench from -5° to 0° and lock with a screwdriver.
- When operating manual override, back off 5° from full open mechanical stop to ensure proper release.
- Do not attempt to use the manual override with actuators mounted in tandem. Damage to the gear train may occur.

Federal Communications Commission (FCC)

This equipment has been tested and found to comply with the limits for a Class B digital device, pursuant to Part 15 of the FCC Rules. These limits are designed to provide reasonable protection against harmful interference in residential installations. This equipment generates, uses, and can radiate radio frequency energy and may cause harmful interference if not installed and used in accordance with the instructions. Even when instructions are followed, there is no guarantee that interference will not occur in a particular which can be determined by turning the equipment off and on; the user is encouraged to try to correct the interference by one or more of the following measures:

- Reorient or relocate the receiving antenna.
- Increase the separation between the equipment and receiver.
- Connect the equipment to an outlet on a circuit different from that to which the receiver is connected.
- Consult the dealer or an experienced radio/television technician for help.

Canadian Department of Communications (DOC)

This Class B digital apparatus meets all requirements of the Canadian Interference-Causing Equipment Regulations.

Cet appareil numérique de la classe B respecte toutes les exigences du Règlement sur le matériel brouilleur du Canada.

European Standard EN 55022

Notice: This is a Class B digital (European Classification) product. In a domestic environment this product may cause

radio interference in which case the user may be required to take adequate measures.

Enclosure Rating

Notice: Avoid locations where excessive moisture, corrosive fumes, vibration, or explosive vapors are present.

Mounting

Notice: To remain in NEMA 2/IP54 compliance, the MA4X-715X and MA4X-707X series actuators should be mounted with conduit end down.

Mount the SmartX Actuator directly on the damper shaft in locations that clear the maximum dimensions of the actuator case and allow the actuator to be mounted flush to the surface of the terminal box and perpendicular to the damper shaft.

Note: Some terminal boxes have sheet metal screw heads or other protrusions near the damper shaft. In these cases, a spacer or shim may be added under the anti-rotation bracket of the actuator to make the actuator perpendicular to the shaft.

Damper Actuator Sizing

Correct sizing of the actuator is necessary for proper control of dampers. The area of damper that can be controlled by a given actuator is dependent upon the type of damper, the quality of the damper, the pressure drop across the damper in the closed position, and the velocity of the air flow through the damper. To obtain actual damper torque requirements, contact the damper manufacturer.

Damper Shaft Sizing





Use the “Long Damper Shaft” mounting instructions if the damper shaft is at least 3-1/2” (90 mm) long.

Use the “Short Damper Shaft” mounting instructions if the damper shaft is shorter than 3-1/2” (90 mm) or the area around the damper shaft is too narrow to allow standard mounting, as described in the “Short Damper Shaft” mounting section.

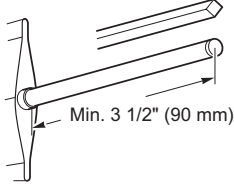
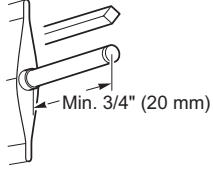
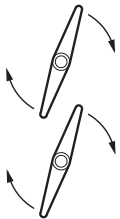
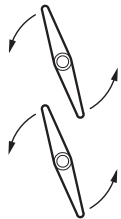
MA40-704X Series Installation

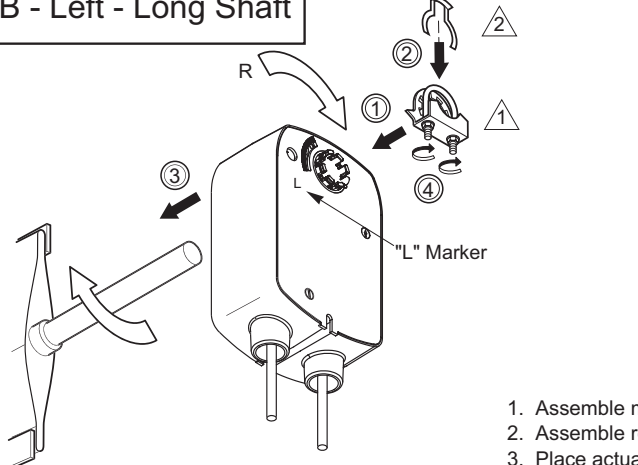
Note: The MA40-704X series actuator comes equipped with standard universal mounting clamp. For damper shafts larger than 5/8" (16 mm) in diameter, the AM-710 universal mounting clamp is required (order separately). The AM-710 clamp accommodates shafts sizes up to 3/4" (19 mm) diameter shafts.

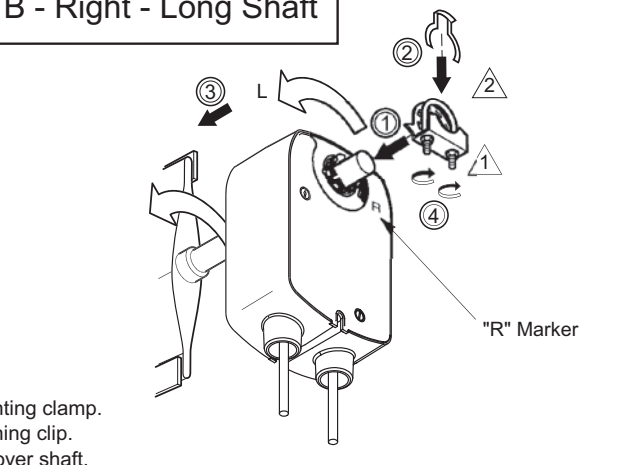
<p>Long Shaft</p>	 <p>Min. 3 1/2" (90 mm)</p> <p>3/8" to 3/4" Diameter (10 mm to 20 mm) 3/8" to 1/2" Square (10 mm to 13 mm)</p>	<p>Short Shaft</p>	 <p>Min. 3/4" (20 mm)</p>
<p>Move the damper to its normal position. Verify the controller action is set to match the damper application.</p> <p>Normally closed damper: when damper is closed, actuator position indicator should be at 0°. When damper is open, actuator position indicator should be at 90°.</p> <p>Normally opened damper: when damper is open, actuator position indicator should be at 0°. When damper is closed, actuator position indicator should be at 90°.</p>			
<p>A - Left</p>	 <p>Shaft Rotates Clockwise To Open</p> <p>This step determines shaft rotation. Linkage may change damper direction.</p>	<p>A - Right</p>	 <p>Shaft Rotates Counterclockwise To Open</p>

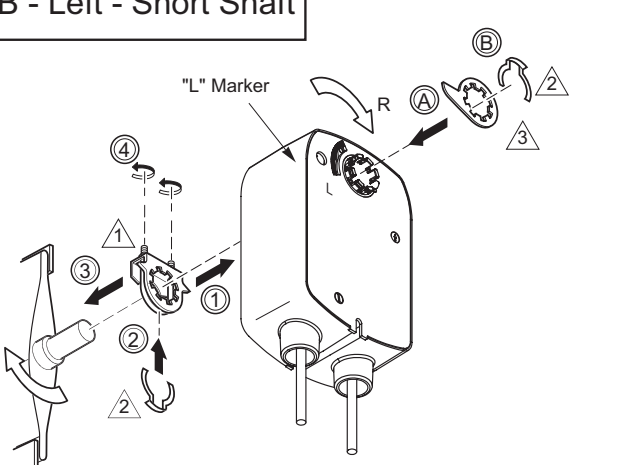
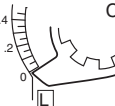
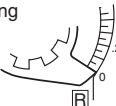
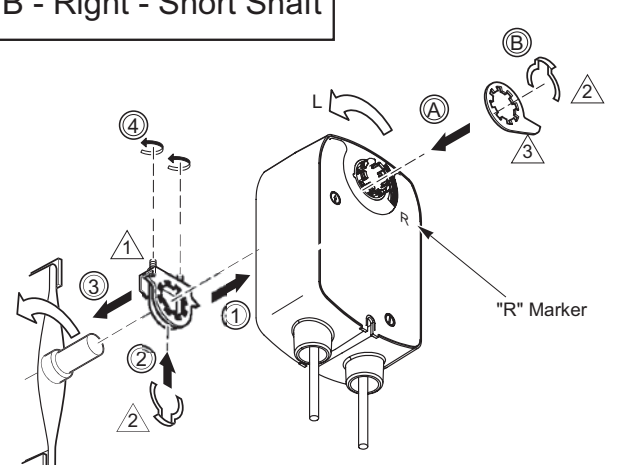
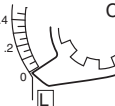
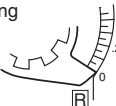
<h3>B - Left - Long Shaft</h3>  <p>1. Assemble mounting clamp. 2. Assemble retaining clip. 3. Place actuator over shaft. 4. Hand tighten clamp nuts.</p> <p>△ 1 Universal mounting clamp. △ 2 Retaining clip.</p> <p>Correct clamp mounting position if actuator is in normal spring return position (before preload)</p>  	<h3>B - Right - Long Shaft</h3>  <p>1. Assemble mounting clamp. 2. Assemble retaining clip. 3. Place actuator over shaft. 4. Hand tighten clamp nuts.</p> <p>△ 1 Universal mounting clamp. △ 2 Retaining clip.</p> <p>Correct clamp mounting position if actuator is in normal spring return position (before preload)</p>  
<h3>B - Left - Short Shaft</h3>  <p>△ 1 Universal clamp. △ 2 Retaining clip. △ 3 Damper position indicator.</p> <p>A. Assemble damper position indicator. B. Assemble retaining clip. 1. Position mounting clamp. 2. Assemble retaining clip. 3. Slide actuator over shaft. 4. Hand tighten clamp nuts.</p> <p>Correct pointer mounting position if actuator is in normal spring return position (before preload)</p>  	<h3>B - Right - Short Shaft</h3>  <p>△ 1 Universal clamp. △ 2 Retaining clip. △ 3 Damper position indicator.</p> <p>A. Assemble damper position indicator. B. Assemble retaining clip. 1. Position mounting clamp. 2. Assemble retaining clip. 3. Slide actuator over shaft. 4. Hand tighten clamp nuts.</p> <p>Correct pointer mounting position if actuator is in normal spring return position (before preload)</p>  

C - Left and Right

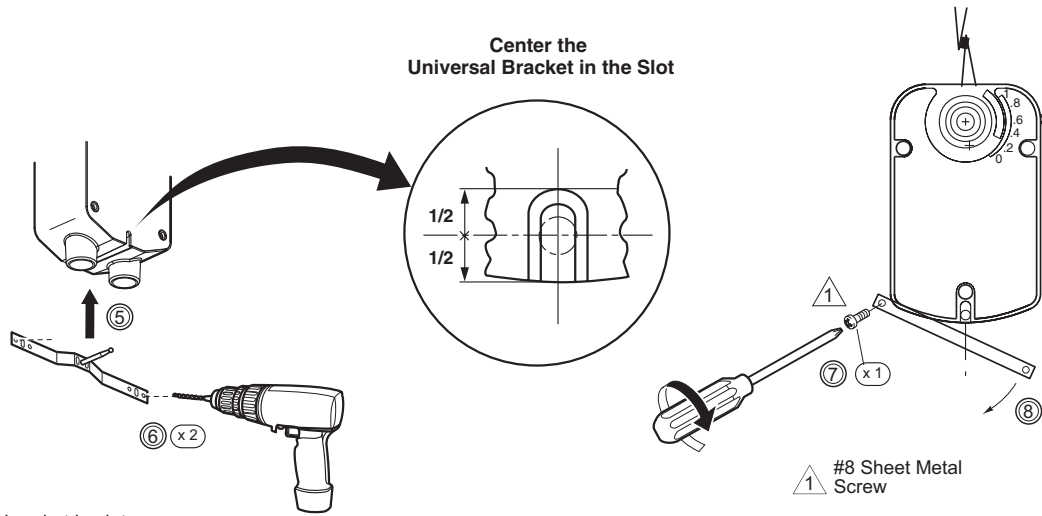

5. Center bracket in slot.
6. Drill two holes.
7. Start one screw.
8. Swing bracket down.

D- Left

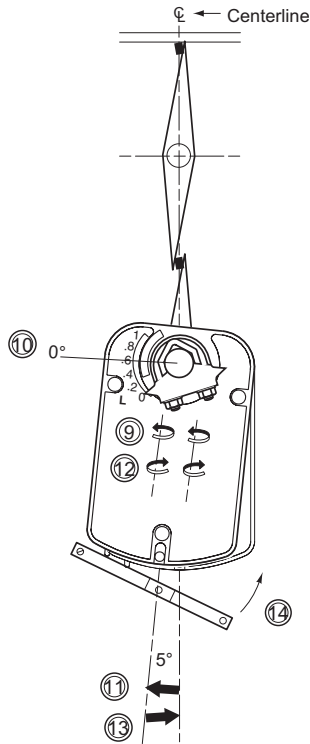

D- Right

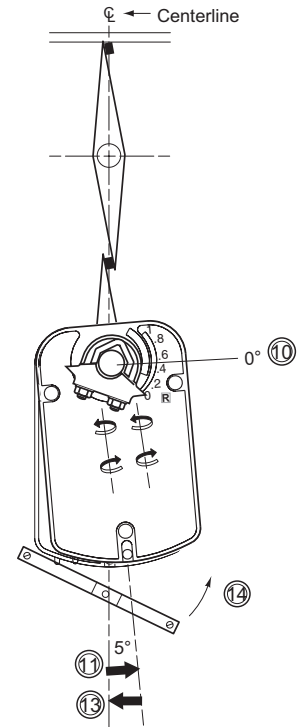

9. Loosen clamp nuts.
10. Check that the shaft is in full zero position.
11. Swing actuator 5° in the direction of travel. Do not move shaft.
12. Tighten clamp nuts to 4 to 6 lb-ft (5.4 to 8.2 N-m) of torque.
13. Move bottom of actuator back into position.
14. Pivot bracket back into position.

E- Left

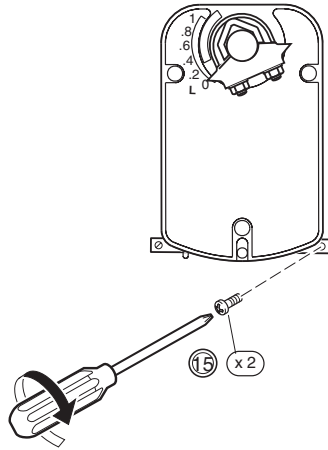

E - Right

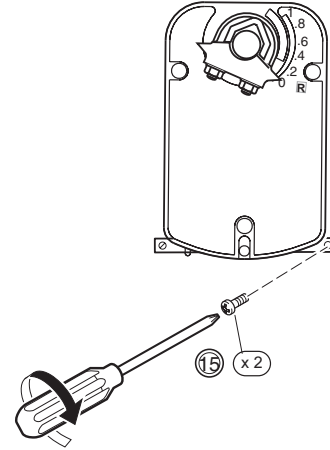

15. Tighten bracket screws.

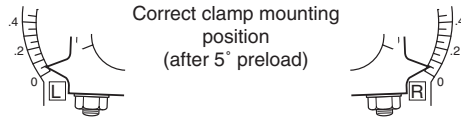

MA41-707X and MA41-715X Series Installation

Caution: Do not drill additional holes in the actuator body. Six pre-drilled holes are located on each side, under the label, to accept #10-24 thread-forming screws for mounting accessories.

Note: The MA41-707X and MA41-715X series actuators come equipped with standard universal mounting clamp installed. For damper shafts larger than 3/4" (19 mm) in diameter, the AM-687 universal mounting clamp is required (order separately). The AM-687 clamp accommodates round shaft sizes up to 1.05" (27 mm) in diameter or 5/8" (16 mm) square shafts.

Caution: The MA41-707X and MA41-715X actuators are equipped with a manual override.

The manual override to be used only when power is not applied to the unit.

If the universal clamp is not set to 0° on the position indicator, manually wind the actuator in the direction indicated with hex wrench from -5° to 0° and lock with a screwdriver.

When operating manual override, back off 5° from full open mechanical stop to ensure proper release.

Do not attempt to use the manual override with actuators mounted in tandem. Damage to the gear train could occur.

Using power tools to adjust the manual override will cause damage to the gears.

To unlock manual override without power, crank the manual override in the direction indicated a minimum of 5°.

Long Shaft	<p>Min. 3 1/2" (90 mm)</p>	Short Shaft	<p>Min. 3/4" (20 mm)</p>
<p>3/8" to 3/4" Diameter (10 mm to 20 mm) 3/8" to 1/2" Square (10 mm to 13 mm)</p> <p>Move the damper to its normal position. Verify the controller action is set to match the damper application.</p> <p>Normally closed damper: when damper is closed, actuator position indicator should be at 0°. When damper is open, actuator position indicator should be at 90°.</p> <p>Normally opened damper: when damper is open, actuator position indicator should be at 0°. When damper is closed actuator position indicator should be at 90°.</p>			
A - Left	<p>Shaft Rotates Clockwise To Open</p>	A - Right	<p>Shaft Rotates Counterclockwise To Open</p>
<p>This step determines shaft rotation. Linkage may change damper direction.</p>			
B	<p>For MA41-707X and MA41-715X only (manual override).</p>		
<p>If position indicator does not point to zero: Unlock the actuator. Insert hex wrench into manual override. Crank the actuator so the indicator points to 0°. Lock the actuator.</p> <p>Manual Override</p> <p>Unlock</p> <p>Fully engage hex wrench into manual override before winding.</p> <p>Caution: Do not crank the manual override if power is applied to the actuator.</p>			

C - Left - Long Shaft

1. Assemble mounting clamp.
2. Assemble retaining clip.
3. Place actuator over shaft.
4. Hand tighten clamp nuts.

1 Universal mounting clamp.
2 Retaining clip.

C - Right - Long Shaft

1. Assemble mounting clamp.
2. Assemble retaining clip.
3. Place actuator over shaft.
4. Hand tighten clamp nuts.

1 Universal mounting clamp.
2 Retaining clip.

For MA41-707X and MA41-715X actuators:

Correct clamp mounting position if actuator is locked with 5° preload.

C - Left - Short Shaft

1. Position mounting clamp.
2. Assemble retaining clip.
3. Slide actuator over shaft.
4. Hand tighten clamp nuts.

A Assemble damper position indicator.
B Assemble retaining clip.

C - Right - Short Shaft

1. Position mounting clamp.
2. Assemble retaining clip.
3. Slide actuator over shaft.
4. Hand tighten clamp nuts.

A Assemble damper position indicator.
B Assemble retaining clip.

For MA41-707X and MA41-715X actuators:

Correct pointer mounting position if actuator is locked at 5° preload.

D - Left and Right

Center the Universal Bracket in the Slot

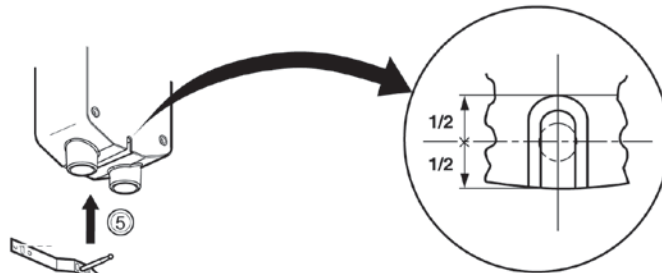

5. Center bracket in slot.
6. Drill two holes.
7. Start one screw.
For MA41-707X and MA41-715X actuators, insert and tighten both screws.

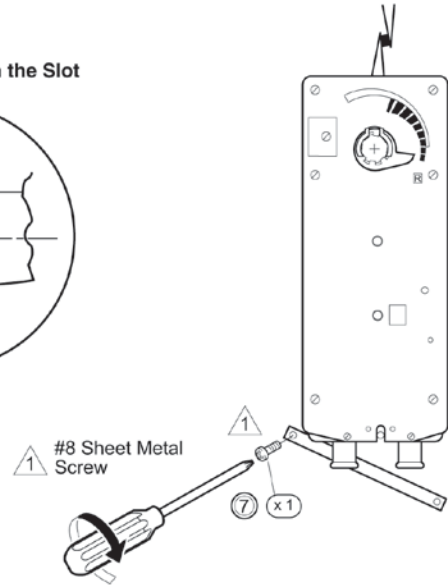

E- Left

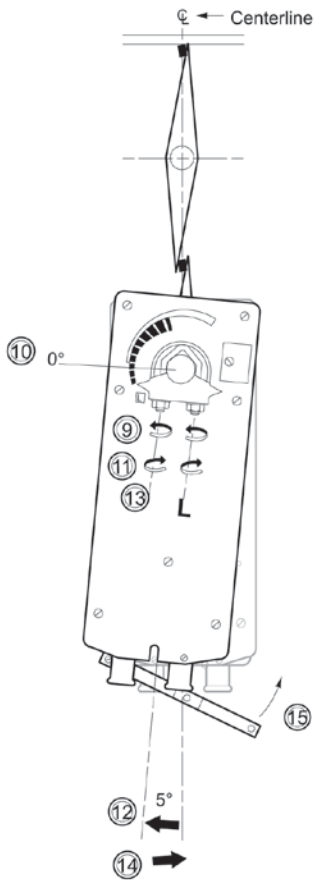

E- Right

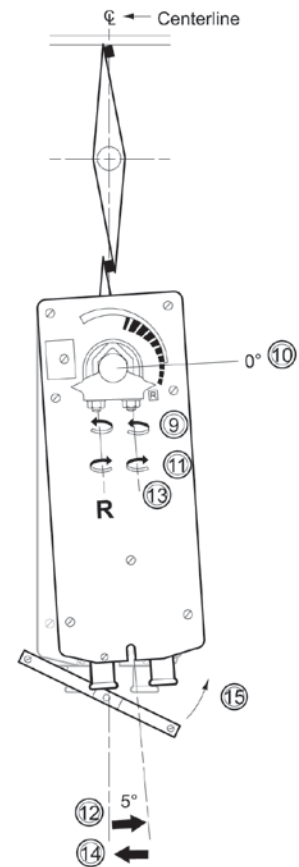

8. Loosen clamp nuts.
9. Check that the shaft is in full zero position.

For MA41-707X and MA41-715X only:
10. Tighten clamp nuts to 8 - 10 ft-lb (11 - 14 Nm).
This completes the installation for MA41-704X and MA41-715X.

F- Left

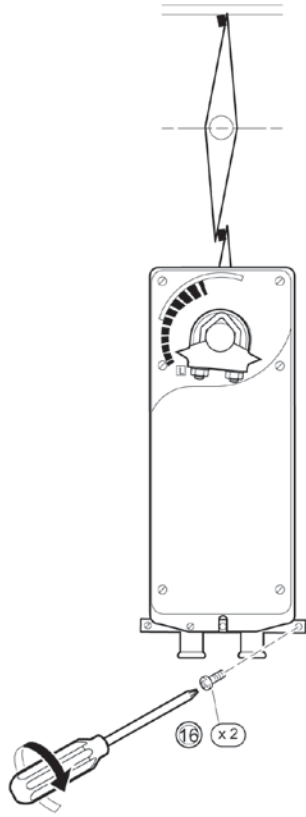

F- Right

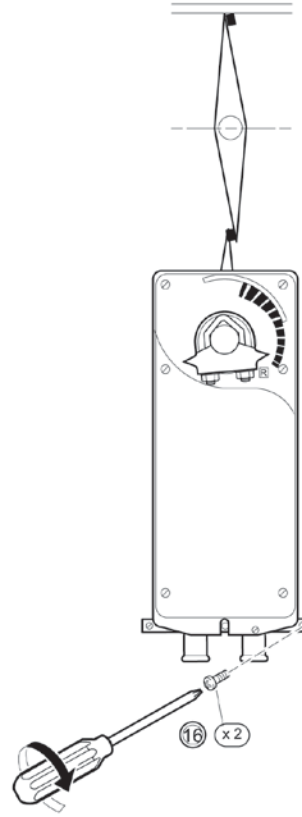

Correct pointer position after mounting.

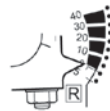

The lock on MA41-707X and MA41-715X will release on first power-up.

Jackshaft Installation

MA40-704X Series

The MA40-704X actuator is designed for use with jackshafts up to 3/4" (19 mm) in diameter. In most applications, the MA40-704X actuator may be mounted in the same manner as a standard damper shaft application. If the jackshaft diameter is larger than 5/8" (16 mm) in diameter, the optional AM-710 universal clamp must be used.

MA41-715X and MA41-707X Series

The MA41-715X and MA41-707X actuators are designed for use with jackshafts up to 1.05" (27 mm) in diameter. In most applications, the actuator may be mounted in the same manner as a standard damper shaft application. If the jackshaft diameter is larger than 3/4" (19 mm) in diameter, the optional AM-687 universal clamp must be used.

Multiple Actuator Mounting

If more torque is required than one actuator can provide a second actuator may be mounted to the damper shaft, using the AM-673 multiple mounting bracket. See Figure-4.

Multiple actuators may be powered from one transformer provided the following rules are followed:

- The total current draw of the actuators (VA rating) is less than or equal to the rating of the transformer and less than the rating of the control circuit.
- Polarity on the secondary of the transformer is strictly followed.
 - All L2 wires from all actuators are connected to the common lead on the transformer.
 - All L1 wires from all actuators are connected to the hot lead.

Caution

Mixing the L2 and L1 wires on one lead of the transformer may result in erratic operation or failure of the actuator and/or controls.

Caution

Do not attempt to use the manual override with actuators mounted in tandem. Damage to the gear train may occur.

Multiple actuators positioned by the same control signal may be powered from multiple transformers provided the following rules are followed:

- The transformers are properly sized.
- All L2 wires from all actuators are tied together and tied to the negative lead of the control signal.

Table 2. Power Wiring Color Code.

Part Number	L1	L2
MA41-7XX3 MA41-7XX3-502	Red	Black
MA41-7XX0 MA41-7XXX-502	Black	White
MA41-7XX1 MA41-7XXX-502	Brown	Light Blue

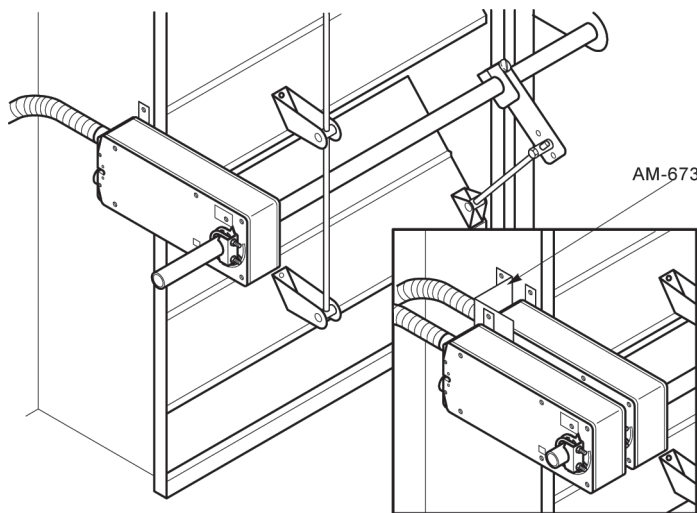

Figure 4 Mounting Multiple Actuators.

Wiring Requirements

Control and Power Leads

See Table-3 for power wiring data. Refer to Figure-1 through Figure-3 for typical wiring applications.

Note: Class 2 control and power lead wiring must be routed separately from line voltage wiring and any other non-class 2 circuits. Line voltage, auxiliary switch, and auxiliary switch leads must be connected to a class 1 circuit.

Table 3. Power Wiring Data.

Actuator Voltage	Part Number	Maximum Wire Run in ft. (m) (5% Voltage Drop)		
		14 AWG	16 AWG	18 AWG
24 Vac 22...30 Vdc	MA41-7153	330 (101)	200 (61)	130 (40)
	MA41-7153-502			
24 Vac 22...30 Vdc	MA40-7043	1100 (335)	700 (213)	440 (134)
	MA40-7043-501			
24 Vac 22...30 Vdc	MA41-7073	600 (183)	500 (152)	254 (77)
	MA41-7073-502			

Auxiliary Switches

The MA40-704X-501 series actuators include one built-in SPDT auxiliary switch which can be used for interfacing or signaling (e.g., for fan start-up). The switch is adjustable between 15° and 95° of rotation (MIN to 1 scale).

The MA41-715X-502 and MA41-707X-502 series actuators include two built-in SPDT auxiliary switches which can be used for interfacing or signaling (e.g., for fan start-up). The switch position near the normal (spring return) position is fixed at 5°. The other is adjustable between 25° and 85° of rotation.

Adjusting the Switching Point

Refer to Table-4 for auxiliary switch rating.

Adjusting the switching point for MA40-704X-501

The actuator must be in its normal (spring return) position. Use a flat screw driver to rotate the switch pointer until it is at the desired switch position on the MIN to 1 scale.

Adjusting the switching point for MA41-715X-502 or MA41-707X-502

The actuator must be in its normal (spring return) position. Insert a 1/8" allen wrench into the hex hole located in the center of the adjustable switch pointer.

Rotate the wrench until the switch pointer is at the desired switch position in degrees, from 25 to 85°.

Table 4. Auxiliary Switch Rating.

Part Number	Voltage	Resistive Load	Inductive Load
MA40-7043-501	24 Vac	6A	1.5A
MA40-7040-501	250 Vac	6A	1.5A
MA40-7041-501			
MA41-707X-502	250 Vac	7A	2.5A
MA41-715X-502			

Rotation Limitation for MA40-704X Series

The Stop Block is used in conjunction with the tab on the universal clamp or the AM-709 position indicator. In order to function properly, the clamp or indicator must be mounted correctly.

The Stop Block controls the rotational output of the MA40-704X and MF40-704X-501 actuators. It is used in applications where a damper has a designed rotation that is less than 90°, for example with a 45° or 60° rotating damper.

1. Determine the amount of damper rotation required. The actuator stop block provides limited rotation from 40° to 95°.
2. Loosen the screw securing the stop block to the actuator.

Note: The actuator is shipped with the Stop Block mounted to the "L" side. If the damper application requires the "R" side face the installer, simply remove the Stop Block and screw and move it to the new location.

3. Slide the stop block into position, so that its edge lines up with the degree graduation on the actuator face which corresponds with the required rotation. See Figure-5.
4. Secure the stop block in place.
5. Test the damper rotation by applying power. Re-adjust if necessary.

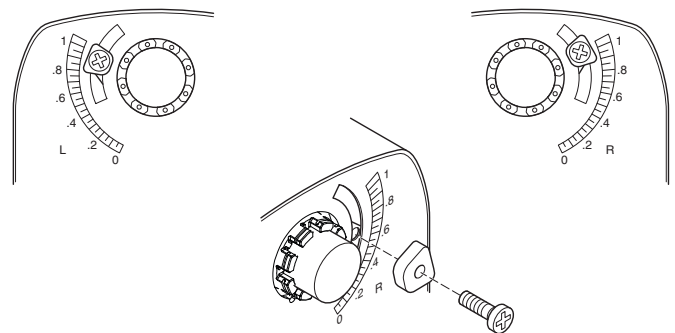

Figure 5 Adjusting Stop Block for Limited Rotation.

Rotation Limitation for MA41-715X and MA41-707X Series

The AM-689 rotation limiter is used in conjunction with the tab on the universal clamp or the AM-686 position indicator which comes with the AM-689. In order to function properly, the clamp or indicator must be mounted correctly.

The AM-689 rotation limiter controls the rotational output of the MA41-715X, MA41-715X-502, MA41-707X, and MA41-707X-502 actuators. It is used in applications where a damper has a designed rotation that is less than 90°, for example with a 45° or 60° rotating damper.

1. Determine the amount of damper rotation required.
2. Locate the AM-689 rotation limiter on the actuator so that its edge lines up with the degree graduation on the actuator face which corresponds with the required rotation. See Figure-6.
3. Find the appropriate cross-hair location through the slot of the rotation limiter. This is the mounting location for the retaining screw.
4. Pierce through the label material to allow easy fastening of the retaining screw.
5. Position the rotation limiter back to the desired position,

making sure the locating “teeth” on the rotation limiter are engaged into the locating holes on the actuator.

6. Fasten the rotation limiter to the actuator using the self-tapping screw provided.
7. Test the damper rotation by applying power. Re-adjust if necessary.

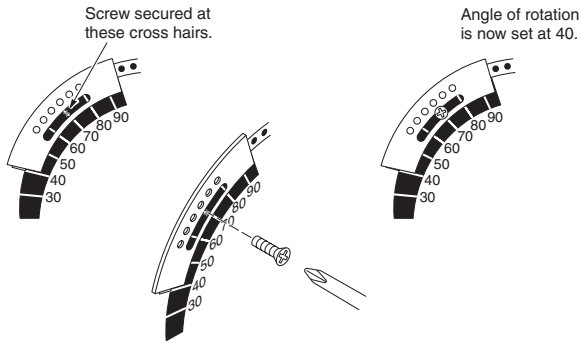

Figure 6 Securing the AM-689 Rotation Limiter.

Checkout

After the entire system has been installed and the actuator has been powered up, the following check can be made for proper system operation. Check for correct operation of the damper while actuator is being stroked.

Apply power to the actuator. Actuator and damper should be driven to their powered position.

On the MA4X-7XXX-50X models, check for correct auxiliary switch operation.

Break power to the actuator. Actuator and damper should return to their normal, or spring return position.

Table 5. Power Wiring Color Code.

Part Number	L1	L2
MA4X-7XX3 MA4X-7XX3-502	Red	Black
MA4X-7XX0 MA4X-7XXX-502	Black	White
MA4X-7XX1 MA4X-7XXX-502	Brown	Light Blue

Theory Of Operation

The actuators are mounted directly onto a damper shaft using a universal V-clamp. When power is applied, the actuator rotates 95° to its powered position, at the same time tensing the spring return safety mechanism. When power is removed, the spring returns the actuator to its normal position. The actuators provide true mechanical spring return operation for reliable, positive close-off on air tight dampers.

The MA41-707X, MA41-707X-502, MA41-715X, and MA41-715X-502 actuators are equipped with a graduated position indicator showing -5° to 90°. The MA40-704X and MA40-704X-501 are equipped with a graduated position indicator showing 0 to 1.

The MA40-704X-501 models are provided with 1 built in auxiliary switch. The SPDT switch is provided for interfacing or signaling, for example, fan start-up. The switching function is adjustable between 15° to 95° rotation (MIN to 1 scale).

The MA41-715X-502 and MA41-707X-502 models are provided with 2 built in auxiliary switches. The SPDT switches are provided for interfacing or signaling, for example, fan start-up. The switching function is adjustable on one switch between 25° to 85° rotation and the other switch is fixed at 5°.

The MA41-707X-XXX and MA41-715X-XXX actuators are equipped with a manual override mechanism. This allows the actuator to be manually positioned at any point between -5° and 85°. This mechanism is accessible on both sides of the actuator and can be used to ensure tight close-offs for valves and dampers. The manual override should not be used while a unit is powered or on units that are mounted in tandem.

Maintenance

Regular maintenance of the total system is recommended to assure sustained optimum performance. The actuators are maintenance free.

Field Repair

None. Replace with a functional actuator.

Dimensional Data

Figure-7 and Figure-8 dimensions are in inches (mm).

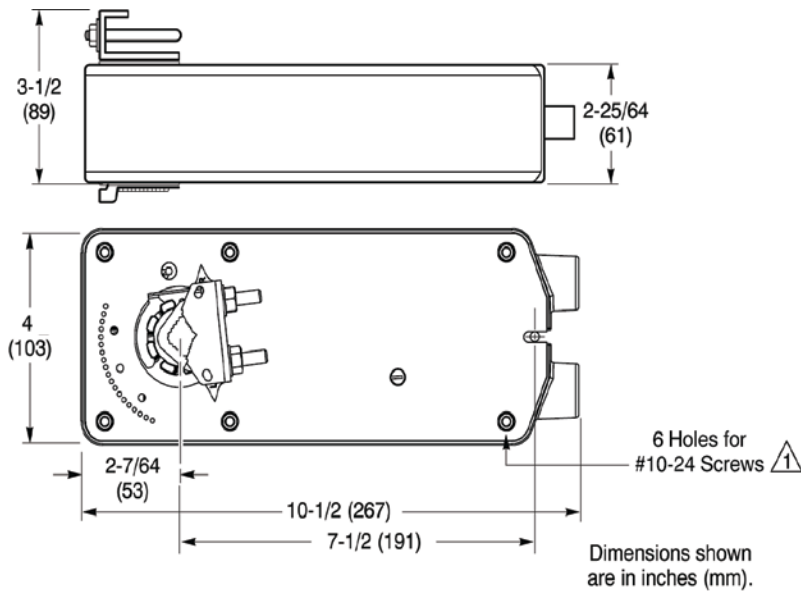

⚠ Note: These are not through holes. Use hardware supplied in Schneider Electric approved AM kits.

Figure 7 MA41-707X or MA41-715X Series Mounting Dimensions.

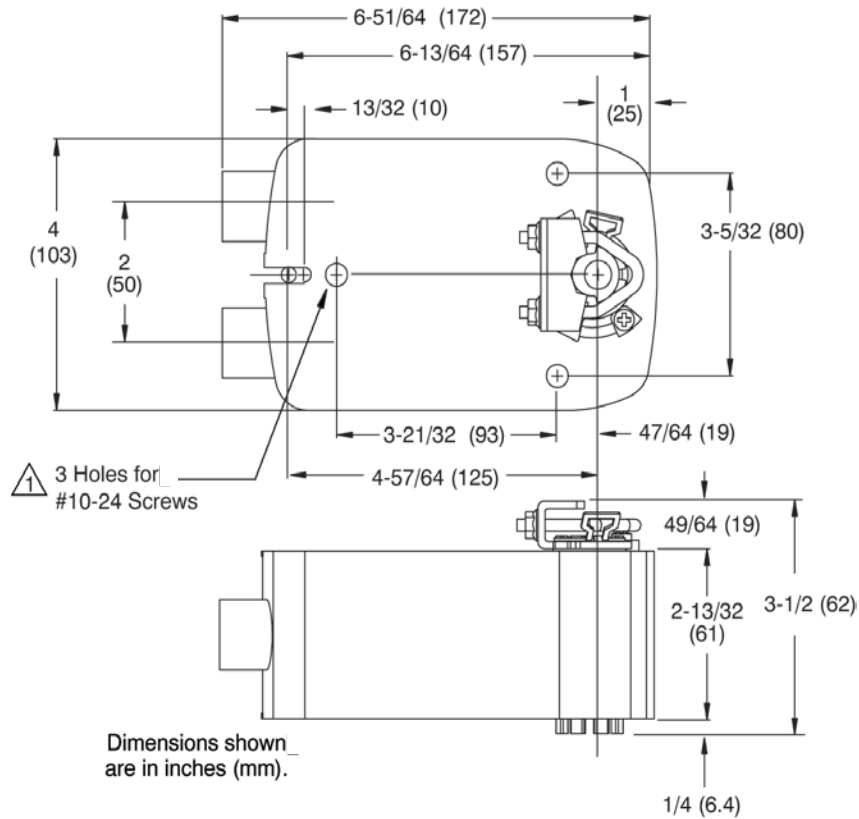

⚠ Note: These are not through holes. Use hardware supplied in Schneider Electric approved AM kits.

Figure 8 MA40-704X Series Mounting Dimensions.